

Surface Mount Technology— You Can Work with It!

Part 2—Last month, we built a couple of simple projects with surface-mount devices. This month's inverter projects go a bit farther.

Projects 2A and 2B— Two 5 V Inverters

A low-current, negative 5 V supply is often a handy item to have on the workbench. Many amplifier circuits are simpler to design using positive and negative voltage sources. Perhaps you have an alphanumeric LCD and found it needs a negative voltage on the **CONTRAST** pin to work. A simple way to supply this negative voltage is to use an ICL7660 voltage inverter, which has been around for a long time. (I'll present another voltage-inverter application in Project 4.) Advances in technology have improved on the '7660. Two ICs I know of that offer significant improvements over their precedents, but both are available only in SM cases: The LM2662 by National is in an SO-8 package and Maxim's MAX871 is available only in SOT-23. Certainly it is possible for manufacturers to make these improved IC versions in a DIP, but neither National nor Maxim have chosen to do so. This appears to me as another signal that the industry is moving toward SM-only parts.

The Technology

Figure 9 shows how these voltage-inverter ICs operate internally. Each consists of four CMOS switches (S1 through S4) sequentially operated by an internal oscillator. During the first time interval, S1 and S3 are closed and S2 and S4 are open; the +5 V input charges C1 with its + terminal being positive and the opposite terminal at ground. At time interval two, S1 and S3 are open and S2 and S4 are closed. There is still 5 V across C1 with the pin 2 side being positive, but pin 4 is no longer at ground potential. The 5 V charge across C1 is transferred to C2—and since C2's positive side is connected to ground—the other side must be 5 V lower than ground, or -5 V. The reason the SM switches can

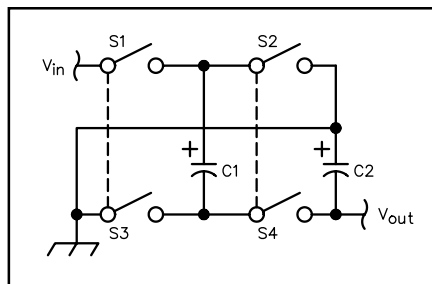

Figure 9—Diagram of the internal workings of the three voltage inverters. See the text for an operational explanation.

handle more current and still be physically smaller is related to their lower resistance and, since both operate at higher frequencies, smaller-value capacitors can be used for a given current output. For best efficiency, low ESR (equivalent series resistance) capacitors should be used. An input bypass capacitor (the value of which depends on the IC and application) improves performance if the power source has a high impedance.

With the trend toward smaller ICs and fewer IC pins, there are often families of nearly identical but specialized ICs. The LM2662 is one of two nearly identical inverters described in the same data sheet. The other, the LM2663, uses pin 1 as a shut-down control instead of a frequency control. This is a common feature with the new technology because of the ever-increasing use of battery power sources, and is especially useful when the inverter is computer controlled. During shut-down, the IC's current drain is reduced to only 10 μ A. The MAX871, like the LM2662, has a brother described in the same data sheet. The MAX870 is identical to the MAX871n except that it runs at 125 kHz, and although it needs larger capacitors, it draws only 0.7 mA.

Because large-value capacitors increase a circuit's physical size, it's good to know

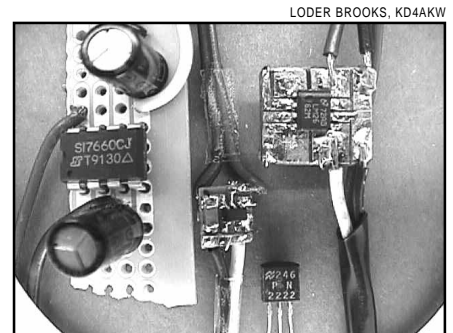

Figure 10—Here, the three voltage-inverter projects are compared in size to a PN2222 transistor.

the minimum capacitance value you can use. This depends on the frequency of operation and the ESR of the capacitor. Nonpolarized capacitor types commonly recommended are Sprague series 593D or 595D, AVX series TPS and the ceramic X7R series. Unfortunately, a capacitor's ESR is often not given in a parts catalog and you may have to consult a data sheet. If you want to try other capacitor values, use the following formulas to calculate output resistance and ripple. Note that C1's resistance is four times as important for reducing resistance as C2, but C1 has no effect on ripple.

$$R_{out} = 2R_{sw} + 1/f \times C1 + 4ESR1 + ESR2 \quad (\text{Eq 2})$$

$$V_{ripple} = I_{load}/f \times C2 + 2I_{load} \times ESR2 \quad (\text{Eq 3})$$

where

- R_{out} = output resistance of the circuit
- R_{sw} = sum of the *on* resistances of the internal switches
- f = frequency of the oscillator driving the inverter
- ESR1 = equivalent series resistance of C1
- ESR2 = equivalent series resistance of C2

¹⁶Notes appear on page 50.

Figure 11—At A, schematics of the LM2662 and MAX871 inverter circuits. Nonpolarized ceramic capacitors are used in the MAX 871 circuit. See Table 1 for suggested capacitance values. The etchless homemade board layouts (B) show where the copper foil is scored to produce component-mounting islands and how the components are mounted on opposite sides of each board. Wire jumpers made of #26 enameled wire (labeled A, B, C and D) interconnect islands of the top foil to those on the bottom.

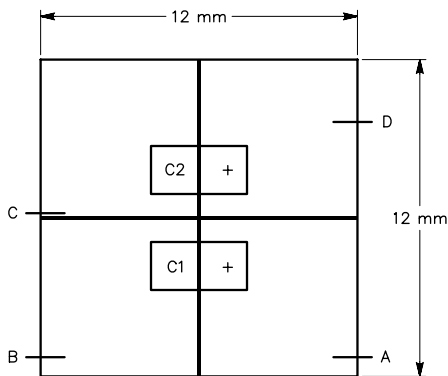
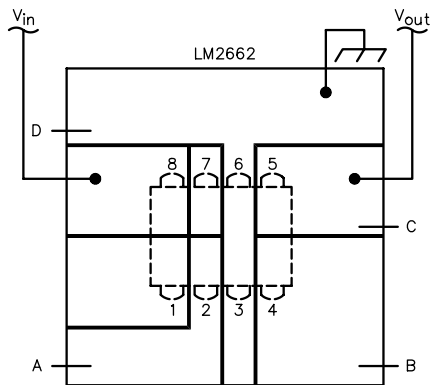
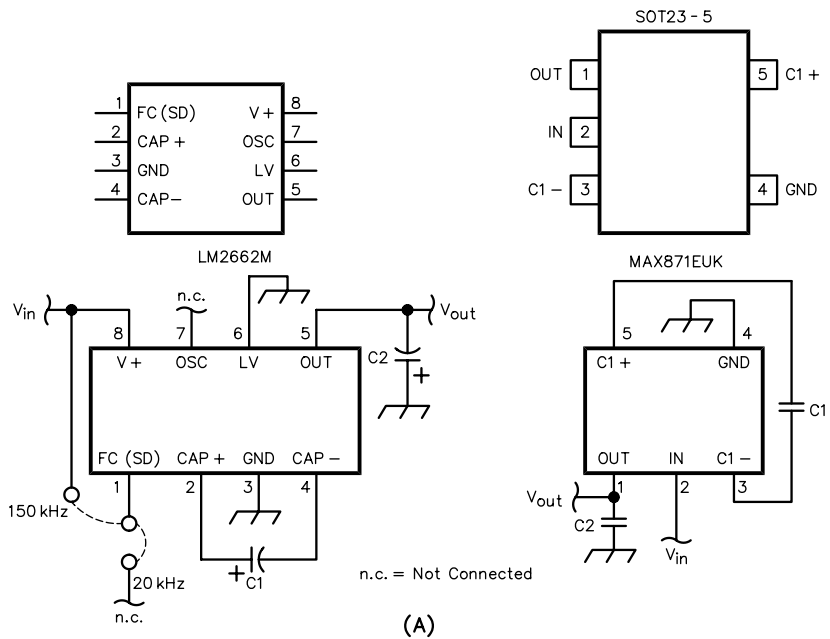

Top

(B)

Bottom

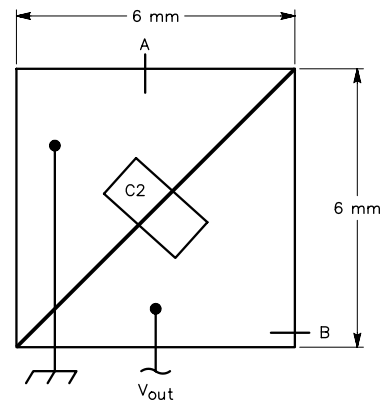
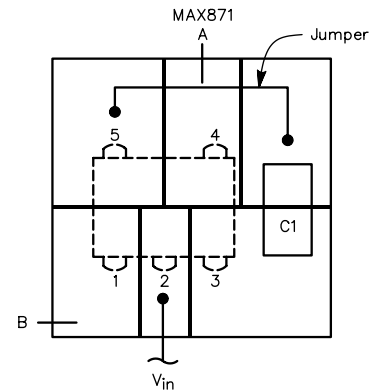

V_{ripple} = peak-to-peak ripple voltage at the output

I_{load} = load current delivered by the inverter

All three ICs can be used in other modes, such as voltage doublers, connected in cascade to increase output voltage, or connected in parallel to increase output current. For information on circuits to use and more information about design

considerations, refer to the device data sheets.

The SOT-23 is a popular IC size and it is important to develop the skills to work with it if you want to make full use of the new technology. When you build the MAX871 project, set it aside because you may find it useful in Project 4.

Table 1 summarizes some features of the ICs mentioned, and Figure 10 shows

you what the three completed circuits look like. You can see that the LM2662 circuit is somewhat smaller than the '7660, yet it provides 10 times the current output! The MAX871 circuit is extremely small and outperforms the ICL7660.

Figures 11A and 11B show the schematics and board layouts, respectively. The circuits are simple, each requiring but two capacitors and one IC.¹⁷

Table 1

	ICL7660	LM2662	MAX871
Package	DIP, SO-8, Can	SO-8	SOT-23
Circuit Resistance (Ohms)	55	3.5	25
Osc Frequency (kHz)	10	20	500
Recommended Cap (μ F)	10	100	0.2
V_{out}^* @ $I = 0$	10.0	10.0	10.0
$I = 14$ mA	9.41	9.97	9.71
$R = 100\Omega$	6.30	9.66	8.04
I_{supply} (mA)	0.17	0.30	2.7

*These figures are based on actual circuit measurements with the load connected between the positive and negative outputs.

Building the LM2662 Circuit

To save space, I put the IC on one side of a double-sided board, mounting the capacitors on the opposite side. Interconnections between the two board sides are made by short pieces of #26 enameled wire. The wires (labeled A, B, C, D in Figure 11B) bend around the edge of the board. If you have built Project 1, you will have no problem with this one. Be careful to observe capacitor polarity. Even though the LM2662 is smaller than the ICL7660, it offers more features. Pin 1 (which is not used in the ICL7660) controls the LM2662's internal oscillator. The inverter runs at 20 kHz when this pin is left unconnected, and at 150 kHz when connected to V_{CC} . If you want the circuit to operate at 150 kHz, add a jumper between pins 1 and 8 of the IC. This allows you to use smaller capacitors, but at the price of a higher supply current.

Building the MAX871 Circuit

The first time you see this project,

you may think "It's too small to build by hand!" But I've built four different circuits this size and made a PC board for each one—so can you! Because the SOT-23 package is smaller than the SO-8, I used a 0.005-inch wheel to make the island-separating cuts on my PC board. Although the IC's pins are small and closely spaced, the SOT-23-5 board requires only two critical cuts: those between pins 1 and 2 and between pins 2 and 3. The spacing between pins 4 and 5 is as large as that of an SO-8 package. Mounting C2 beneath the board makes component layout much easier.

SOT-23 packaged devices are too small for manufacturers to imprint the part number on them—MAX890EUK just will not fit! Instead of MAX890EUK, Maxim uses the marking **ABZO**. If you get two SOTs mixed up, you will have to consult the data sheets to determine which is which.

Next Month

In Part 3, we'll look at a low-voltage

battery protection switch that makes use of a few SM ICs: three SO-8s and one SOT-23.

Notes

¹⁶Part 1 of this four-part series appears in the April 1999 issue of *QST*, pp 33-39.

¹⁷Obtaining the parts—Project #2A: Gerber Electronics stocks the LM2662 and Newark Electronics stocks low-ESR tantalum SM capacitors. If you cannot find an LM2662, use the LM2660, Maxim MAX660 or the Linear Technology LTC660; all have similar characteristics and identical pin outs. Digi-Key carries some of these ICs, but does not stock the low ESR SM capacitors. Low-ESR SM capacitors are quite expensive, so you may want to use standard tantalum capacitors instead. These are available from most suppliers. I have a PC board for the layout described; price: \$1.50. Contact Sam Ulbing, N4UAU, 5200 NW 43rd St, Suite 102-177, Gainesville, FL 32606; n4uau@afn.org. Credit cards are *not* accepted.

Project #2B: A limited number of parts kits, with hard-to-find 1 μ F ceramic capacitors (to permit maximum current output with minimum ripple) are available from me for \$6 *without* a PC board. If you want a pre-made PC board add, \$1.25. (Florida residents add sales tax.)

If you are interested in making your own boards as described, I have a limited number of parts kits consisting of a 3x6-inch double-sided, copper-clad board, eight cutoff wheels (two 0.005 inch, four 0.009 inch and two 0.025 inch diameter) and the special mandrel recommended for use with the ultra-fine cutoff wheels. Price: \$13. This kit allows you to make the boards for all the projects in this series and more. (Florida residents must add sales tax. For orders outside the US, please add \$3 for shipping.)

You can contact Sam Ulbing, N4UAU, at 5200 NW 43rd St, Suite 102-177, Gainesville, FL 32606; n4uau@afn.org. 